



NEXTBMS

BMS Alliance 4th Webinar: Electrochemical battery models and their role in future cloud-supported battery management systems

Igor Mele, Samo Penič, Klemen Zelič, Tomaž Kutrašnik

University of Ljubljana, Faculty of Mechanical Engineering

RESEARCH



Univerza v Ljubljani



INDUSTRY



SERVICE



About the project

Acronym: NEXTBMS

Duration: 42 months

Start date: 01-06-2023

Total budget: 4.998.318,25 €

EC Funding: 4.998.318,25 €

GA: 101103898

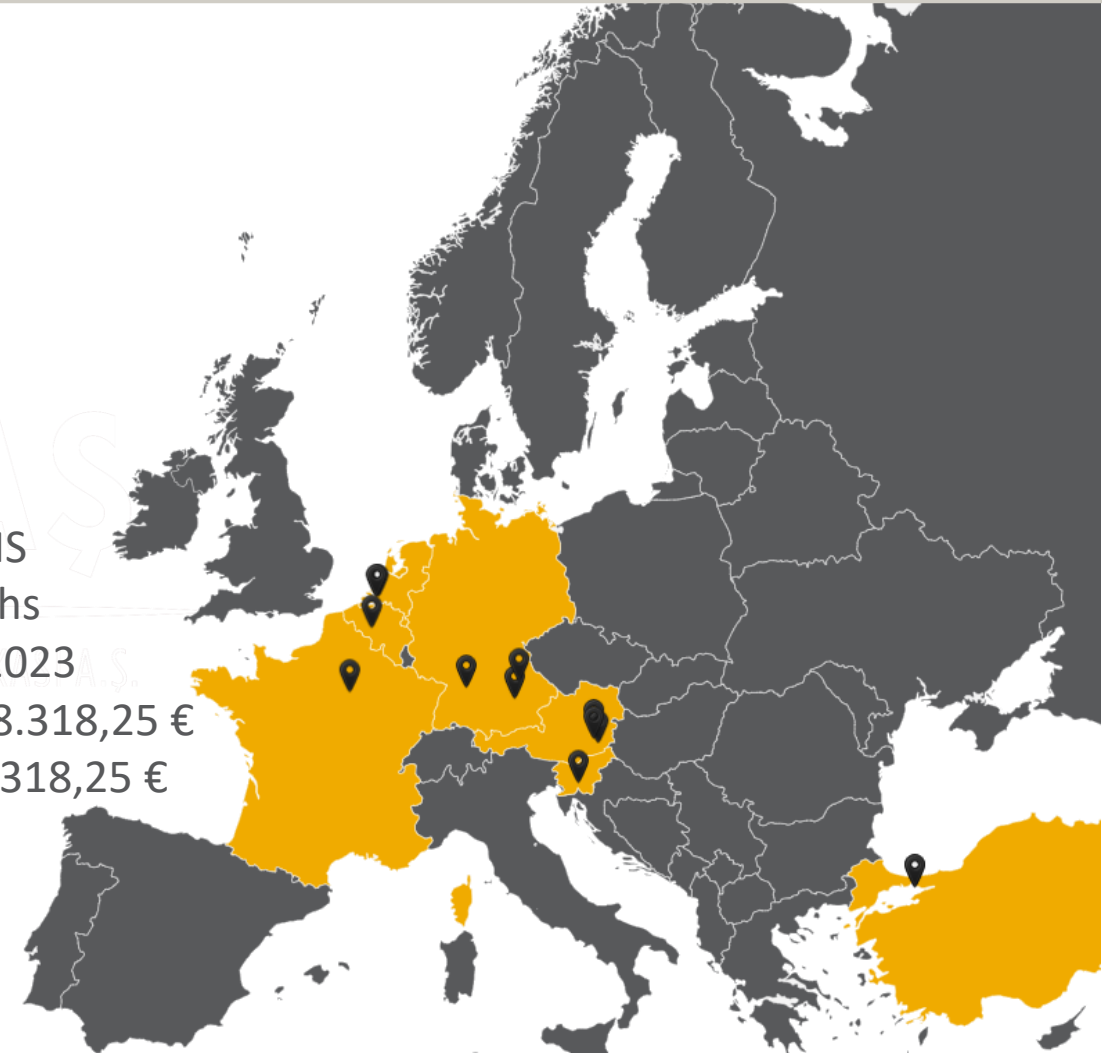

High-level concept and BMS model related objectives

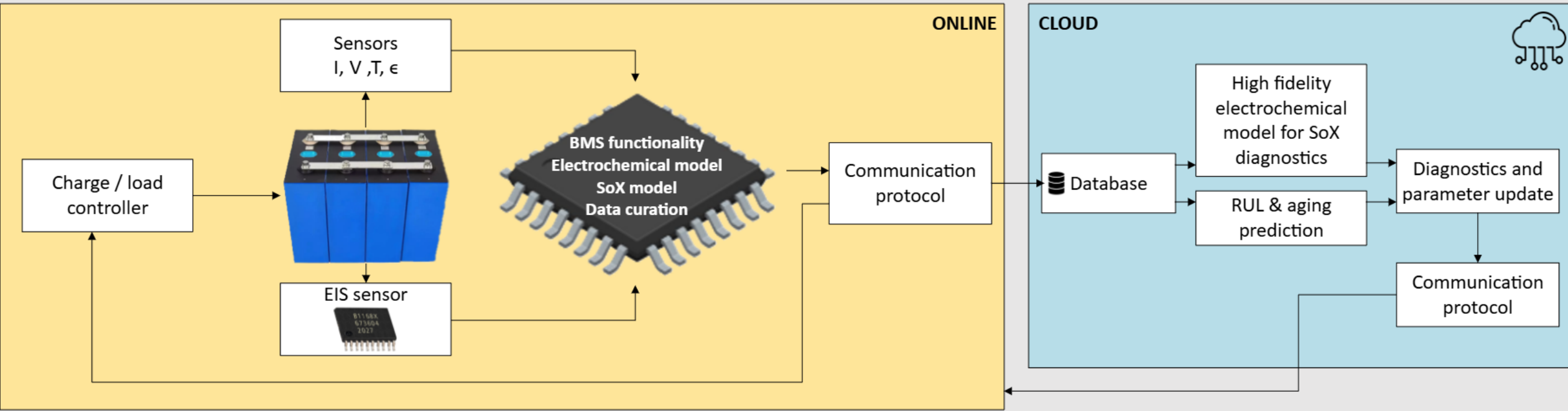

Objectives

- Develop Advanced physics-based and adaptable battery models.
- Deliver advanced data acquisition combining sensor-based solutions at battery system/module level and model generated values.
- Integrate new control algorithms with advanced state estimators and data-based algorithms to increase utilisation while ensuring safety and reliability of the advanced BMS system.

State-of-the-art: Equivalent circuit model

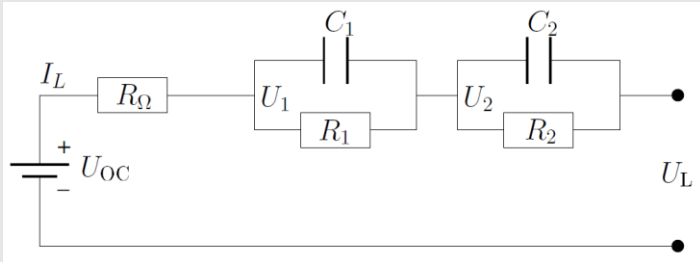

- + Fast and simple for implementation
- + Computationally non-demanding
- Oversimplified and incorrect virtual representation of the battery cell
- Reduced prediction capability outside trained region
- No correlation between RC parameters and physical parameters in basic ECMs

Beyond state-of-the-art: electrochemical model

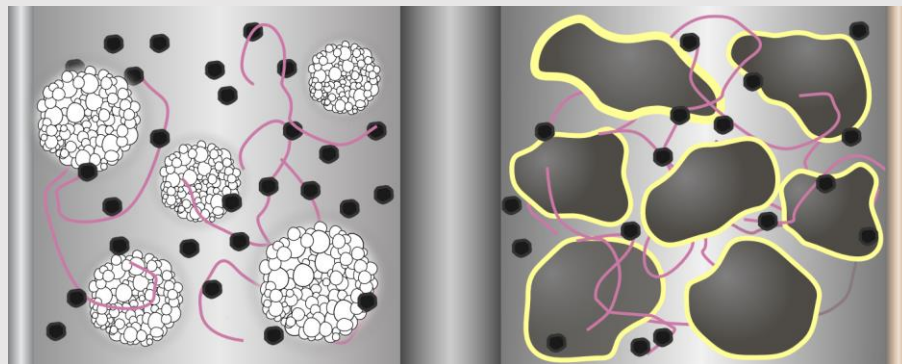
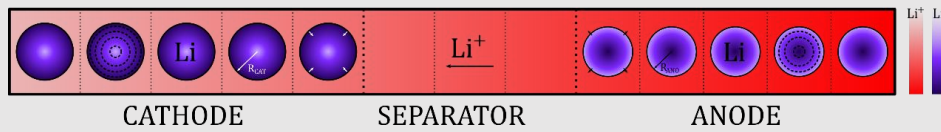

- + Consistent virtual representation of the electrochemical cell
- + Clear correlation between the model parameters and intra-cell phenomena
- + Intra-cell virtual sensing and SoX diagnostics capability
- Computationally more demanding, yet NEXTBMS demonstrated computationally optimized and microchip implementable version of the electrochemical model
- Parametrisation requires advanced electrochemical characterisation

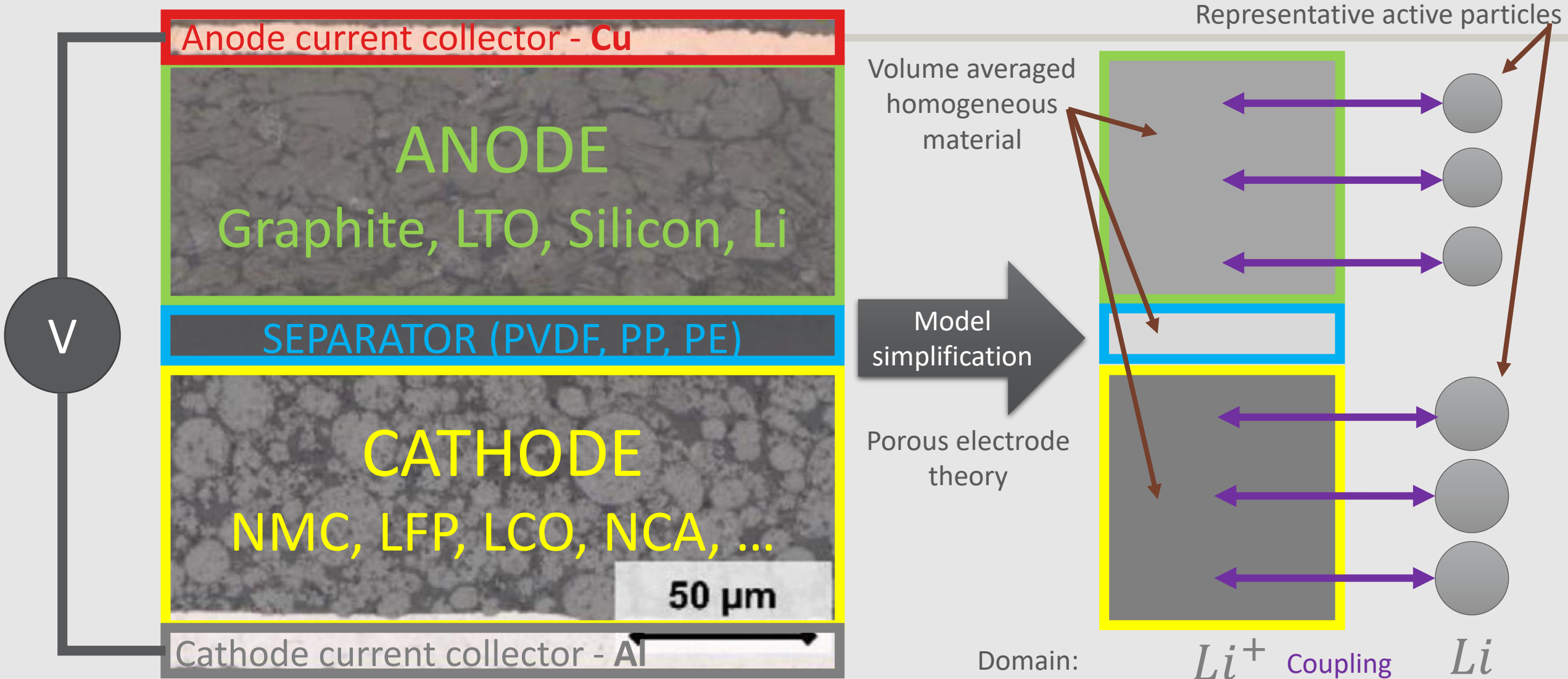

Simplified example of processes when discharging the cell (vice-versa when charging)

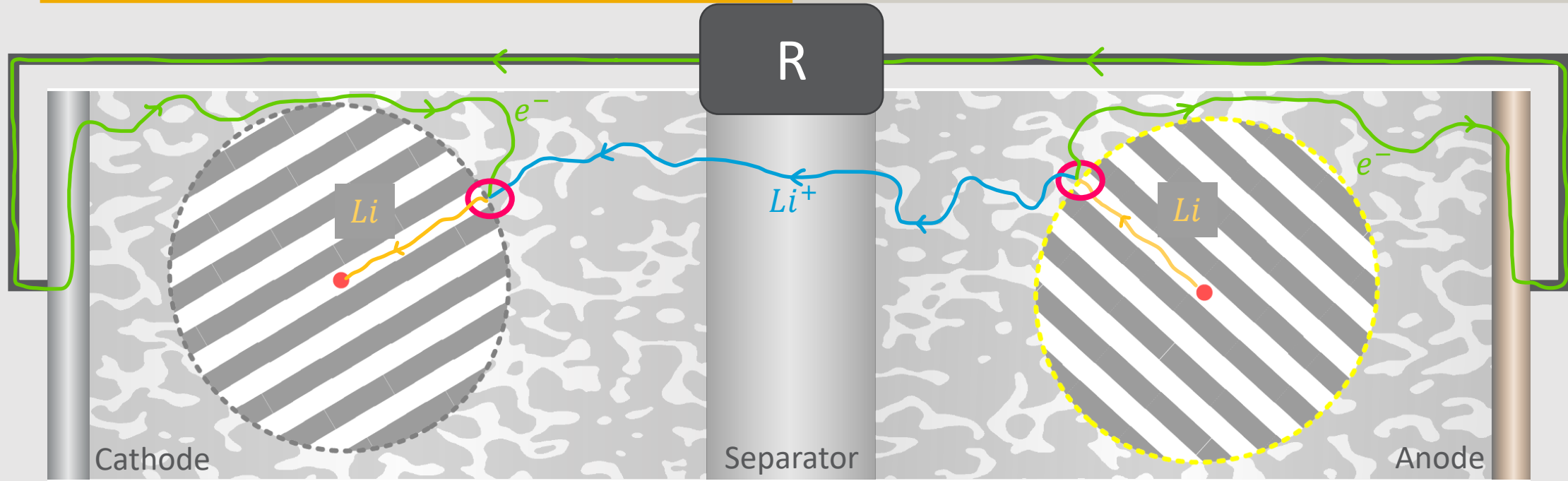

Note: Multiparticle and spatially resolved model is used in online and cloud application.

Electrochemical reaction $Li^+ + e^- \rightarrow Li$

$$j_{es} = \frac{i_{0,es}}{F} \left[\exp\left(-\frac{\alpha_c F}{RT} \eta_{es}\right) - \exp\left(\frac{(1-\alpha_a) F}{RT} \eta_{es}\right) \right]$$

Solid phase diffusion of Li

$$\frac{\partial c_s}{\partial t} = \frac{1}{r^2} \frac{\partial}{\partial r} \left(D_s(c_s) r^2 \frac{\partial c_s}{\partial r} \right)$$

Diffusion and potential field of Li^+

$$\frac{\partial(\epsilon_e c_e)}{\partial t} = \nabla \cdot \left(D_e^{eff} \nabla c_e - \frac{t_+}{z_+ F} i_e \right) - a_{es} (j_{es} - j_{es}^{DL}) + a_{ecb} j_{ecb}^{DL}$$

$$\nabla \cdot i_e = \nabla \cdot \left(-\kappa_e^{eff} \nabla \Phi_e + 2 \frac{\kappa_e^{eff} RT}{F} (1-t_+) \left(1 + \frac{\partial \ln f_{\pm}}{\partial \ln c_e} \right) \nabla \ln c_e \right) = -F(a_{es}(j_{tot} - j_{es}^{DL}) - a_{ecb} j_{ecb}^{DL})$$

Potential field of e^-

$$\nabla \cdot i_s = \nabla \cdot (\sigma_s^{eff} \nabla \Phi_s) = F(a_{es}(j_{tot} - j_{es}^{DL}) - a_{ecb} j_{ecb}^{DL})$$

Solid phase diffusion of Li

$$\frac{\partial c_s}{\partial t} = \frac{1}{r^2} \frac{\partial}{\partial r} \left(D_s(c_s) r^2 \frac{\partial c_s}{\partial r} \right)$$

Electrochemical reaction $Li \rightarrow Li^+ + e^-$

$$j_{es} = \frac{i_{0,es}}{F} \left[\exp\left(-\frac{\alpha_c F}{RT} \eta_{es}\right) - \exp\left(\frac{(1-\alpha_a) F}{RT} \eta_{es}\right) \right]$$

The role of electrochemical models

Online and Cloud model approaches

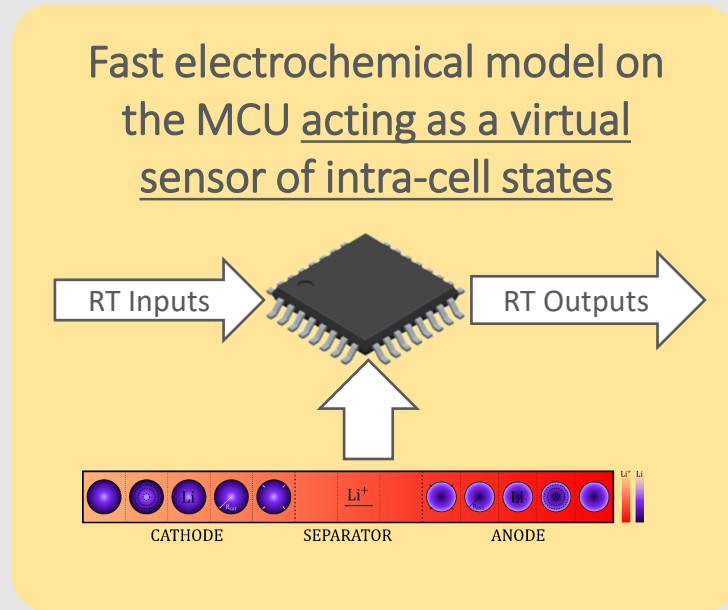

Direct model-to-model parameter transferability

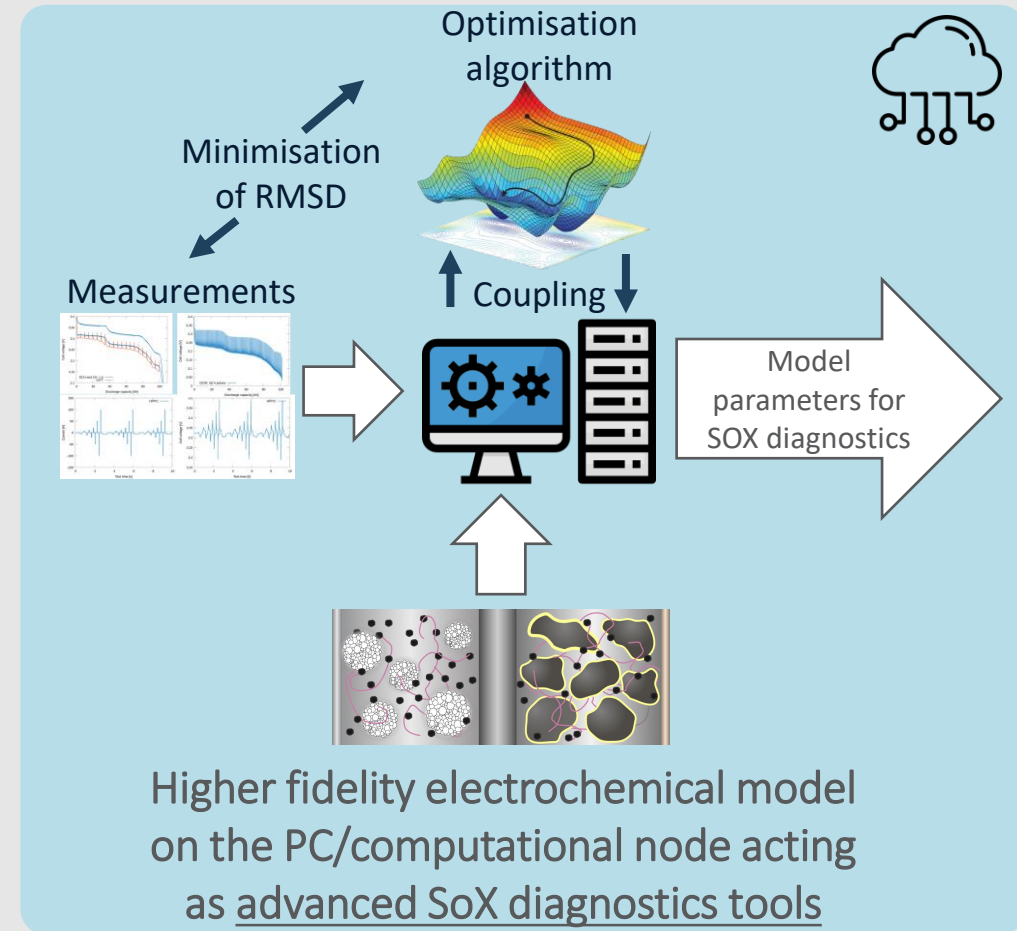

*RT – real time

**RMSD – Root Mean Square Deviation

Specifications of the embedded HW (MCU) in the NEXTBMS project

- MCU family: AURIX TC3xx
- Architecture: TriCore™ 1.6.2 (32-bit multicore)
- CPU cores: 3 × TriCore CPUs (CPU0, CPU1, CPU2)
- Maximum CPU frequency: up to 300 MHz
- Program Flash: up to 6 MB
- Data Flash: up to 768 kB
- RAM:
 - DSPR (Data Scratch-Pad RAM):
 - CPU0: 240 kB
 - CPU1: 240 kB
 - CPU2: 96 kB
 - PSPR (Program Scratch-Pad RAM): 64 kB per core
 - LMU (Local Memory Unit) RAM: up to 1.5 MB shared memory
- Operating Temperature: Automotive-grade (-40 °C to +125 °C junction, depending on variant)
- ISO 26262 ASIL-D (Automotive Safety Integrity Level) capable
- Connectivity: CAN FD Gigabit Ethernet (on Ethernet-equipped variants), FlexRay, LIN, SPI / QSPI, I²C, UART / ASC

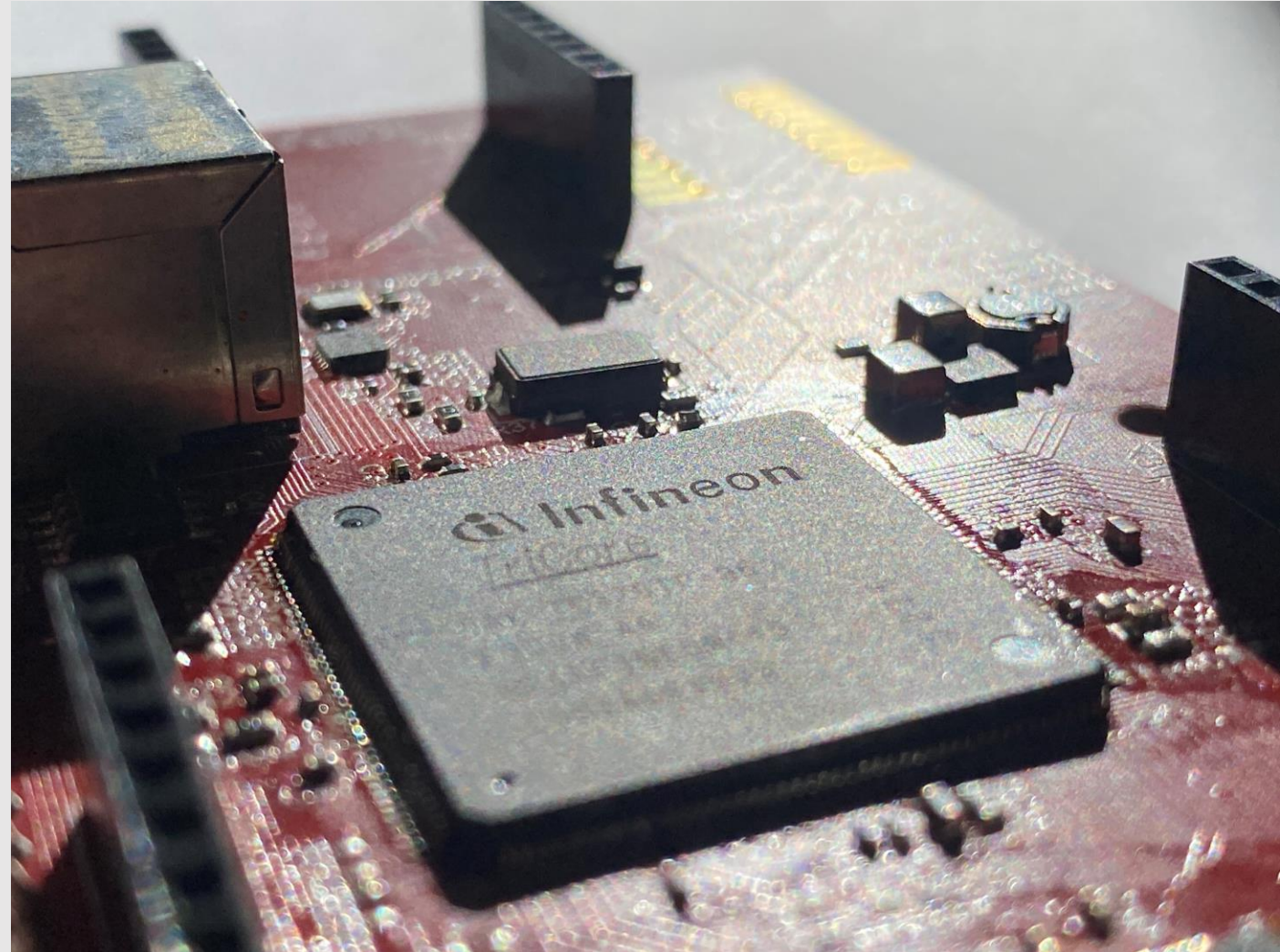

Configuration of the deployed electrochemical model to the MCU

Ncv_CAT	Ncv_SEP	Ncv_ANO	Ncv_par_CAT	Ncv_par_ANO	Heap usage [KB]	RT factor
5	5	5	5	5	210	0.2

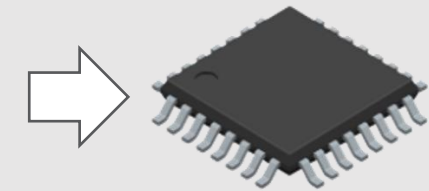
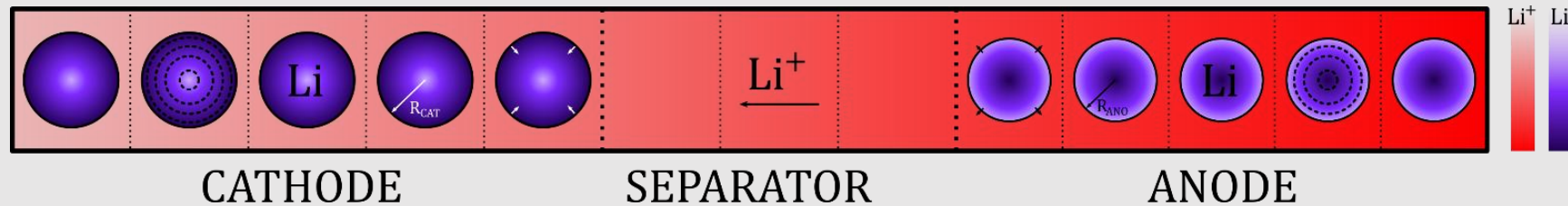

- **Ncv_CAT**: number of control volumes in cathode
- **Ncv_SEP**: number of control volumes in separator
- **Ncv_ANO**: number of control volumes in anode
- **Ncv_par_CAT**: number of control volumes in each cathode particle
- **Ncv_par_ANO**: number of control volumes in each anode particle
- **Heap usage**: amount of allocated memory in the model in kilobytes
- **Real time (RT) factor**: ratio between the actual clock time of the simulation and the simulated time

Advanced virtual sensing features in NextBMS

Electrode potentials

Virtual sensor for cathode and anode potential

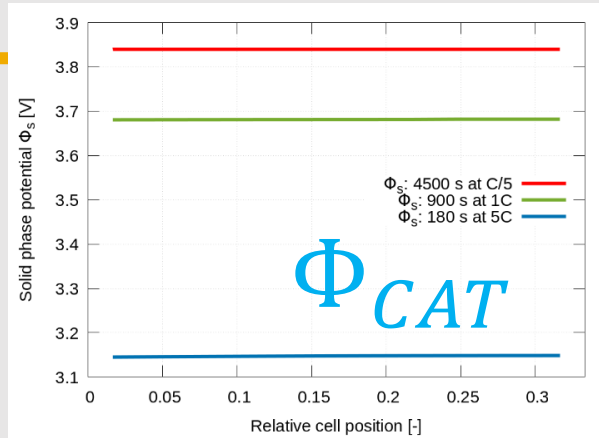

DISCHARGING

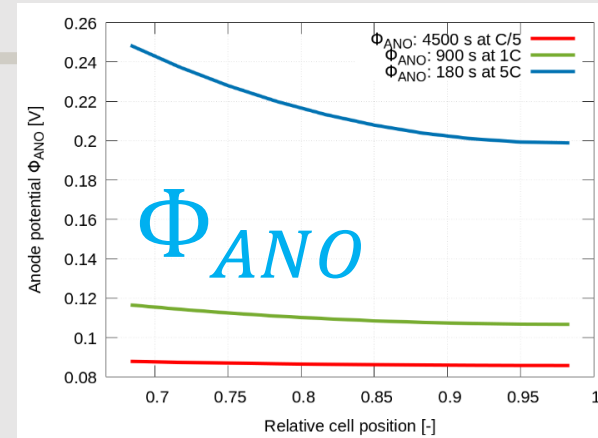

Prediction of the cathode potential during charging to prevent decomposition of the electrolyte and active material degradation

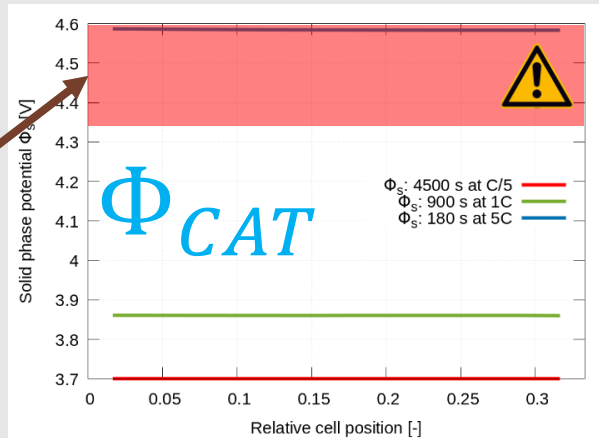

CHARGING

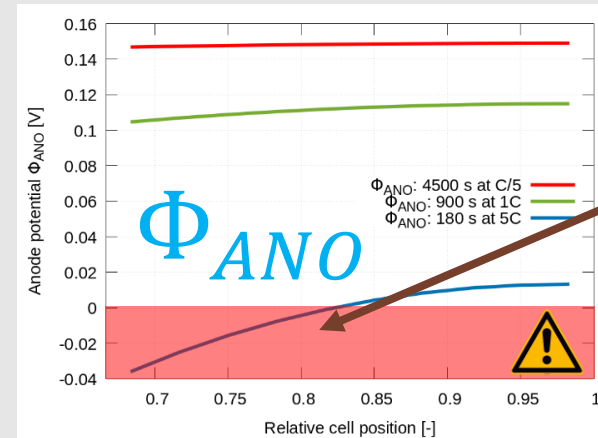

Prediction of the anode potential during charging to prevent occurrence of Li-plating

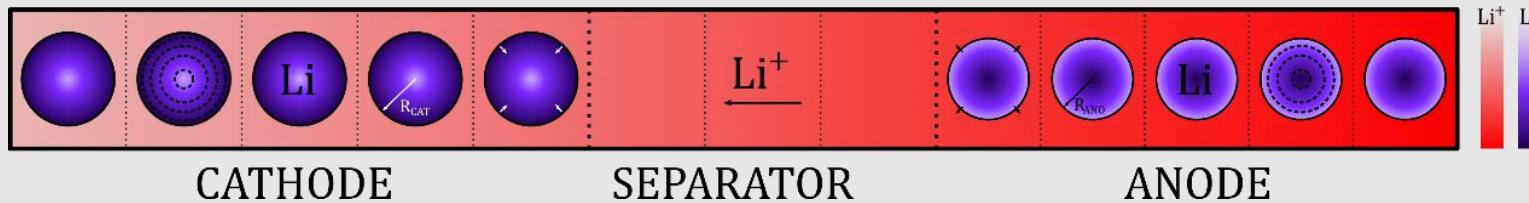

Internal battery cell states during DCH/CH

Fast electrochemical model on the MCU acting as a virtual sensor of intra-cell states

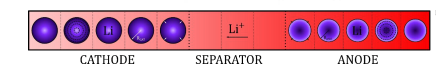
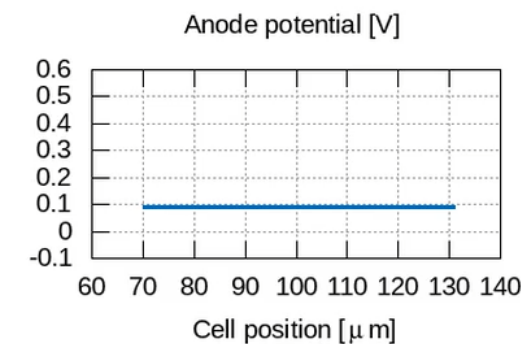
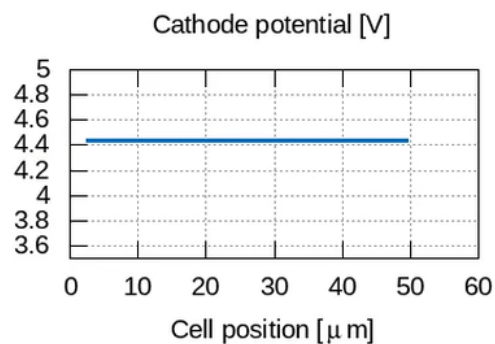
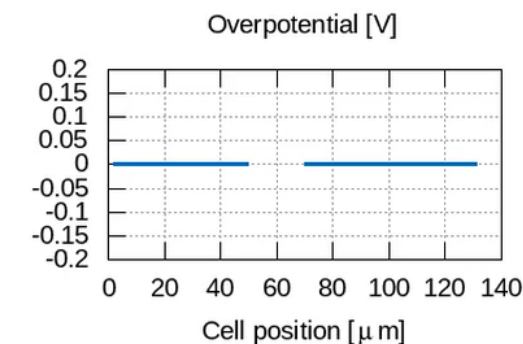
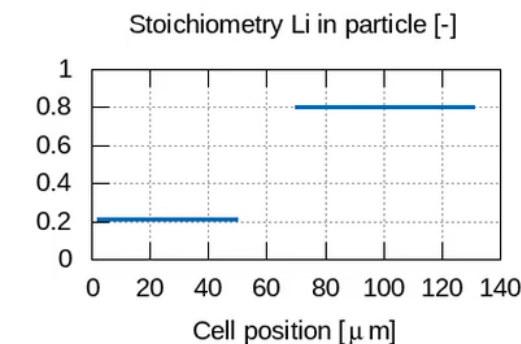
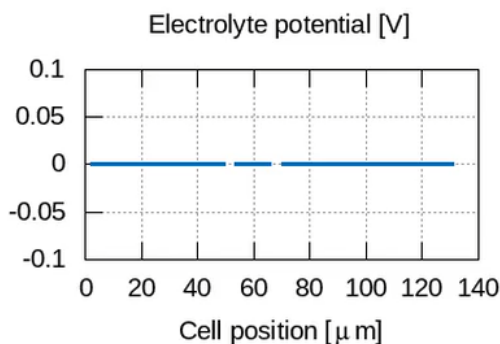
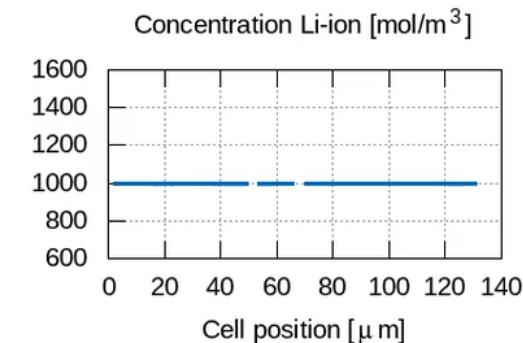
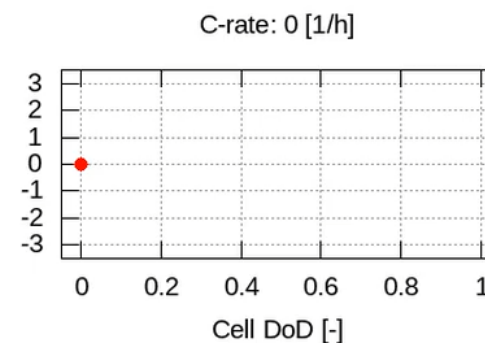
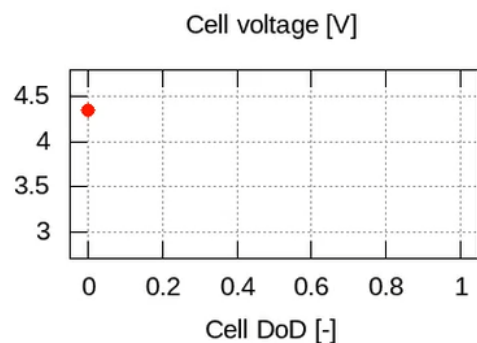
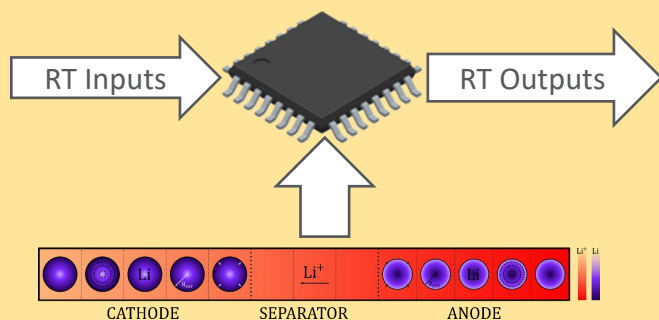

Status: Rest

C-rate: 0 1/h

SoC: 100 %

Cell voltage: 4.35 V

Time: 11 s

Conclusions

- ❖ Current state-of-the art embedded HW is already capable of running electrochemical battery models.
- ❖ Electrochemical models are key enablers for virtual sensing of internal states of the battery cells.
- ❖ Virtual sensing makes possible advanced SoX-aware battery management enabling maximization of battery performance at minimized/acceptable degradation rates.
- ❖ Electrochemical models are key enablers for cloud-based SoX diagnostics.

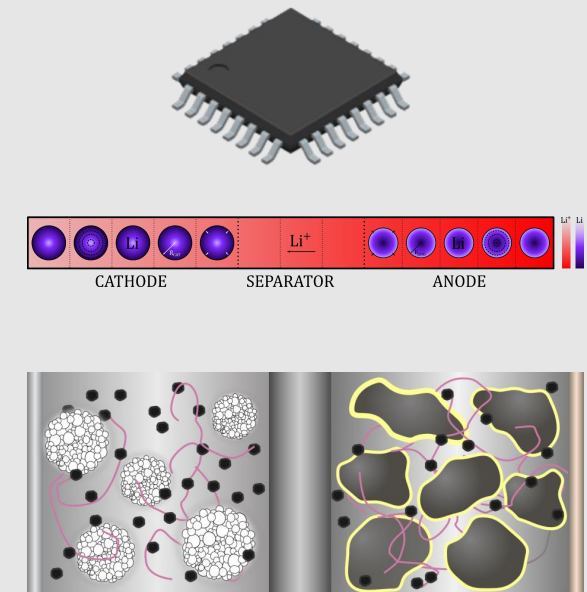



NEXTBMS

Thank you



NEXTBMS.eu

Funded by the European Union under grant number 101103898. Views and opinions expressed are however those of the author(s) only and do not necessarily reflect those of the European Union. Neither the European Union nor the granting authority can be held responsible for them. [NEXTBMS - disclaimer](#)

NEXTBMS – GA No: 101103898 - CONFIDENTIAL



Funded by
the European Union